

# Technical Data Sheet

## Installation of LIGHTGUARD®/HEAVYGUARD® PMR Insulation Panels On A T. Clear Protected Membrane Roof System

### Table Of Contents

PART 1. GENERAL.....	pg. 1
1.01 Description.....	pg. 1
1.02 Work Included.....	pg. 1
1.03 Quality Assurance.....	pg. 1
1.04 Submittals.....	pg. 2
1.05 Related Specification Documents.....	pg. 2
1.06 Delivery, Storage, Handling.....	pg. 2
1.07 Design Considerations.....	pg. 2
1.08 References.....	pg. 2
1.09 Maintenance.....	pg. 3
1.10 Warranty.....	pg. 3
PART 2. PRODUCTS.....	pg. 3
2.01 Manufacturers.....	pg. 3
2.02 Materials.....	pg. 3
PART 3. EXECUTION.....	pg. 4
3.01 Preparation.....	pg. 4
3.02 [Membrane Installation]...	pg. 4
3.03 [Slip Sheet Installation]....	pg. 4
3.04 [Multi-Layer Installation]	pg. 4
3.05 LIGHT GUARD & HEAVYGUARD PMR Insulation Panels Installation.....	pg. 5
3.06 Perimeter Securement.....	pg. 7
3.07 Securement/Tongue & Groove Integrity Lost.....	pg. 9
3.08 Fasteners.....	pg. 10



**In a T. Clear Protected Membrane Roof System using LIGHTGUARD or HEAVYGUARD (LG/HG) Protected Membrane Roof (PMR) Insulation panels, the boards are installed unadhered over the waterproofing membrane with interlocking tongue and grooves and in a staggered-joint array. The system is designed to protect the waterproofing membrane and insulate the roof assembly on both new construction and retrofit applications.**

### Part 1. General

#### 1.01 Description

A. LIGHT GUARD and HEAVYGUARD Protected Membrane Roof Insulation panels (LG/HG PMR) manufactured by T. CLEAR CORP. utilize extruded polystyrene foam, tongue and groove along its long edges, with a nominal 3/8 in. thick latex modified concrete mortar surface facing (15/16 in. thick for HEAVY GUARD). The board size is 2 ft. by 4 ft. and weighs on an average of 4 1/2 lbs. per sq. ft. (11 lbs. per sq. ft. for HEAVY GUARD). Standard foam thicknesses are 2 in. and 3 in.

#### 1.02 Work Included

A. This specification covers the installation of LIGHT GUARD/HEAVY GUARD (LG/HG) PMR Insulation panels. Wind securement required for these systems shall be determined from T. CLEAR CORP. Technical Data Sheet 4.4.

#### 1.03 Quality Assurance

##### A. Compatibility

01. The manufacturer or supplier of the membrane shall be responsible for determining that the membrane is compatible with the roof insulation.

02. Any existing built-up roof (BUR) membrane which has been resaturated within the previous four years must be covered with a slip sheet prior to installation on the product.

## B. Contractor Qualification

01. The contractor shall be currently approved by T. CLEAR CORP. and the membrane manufacturer to install LG/HG PMR Insulation panels and the manufacturer's membrane.

## C. Inspections

01. The T. CLEAR CORP. representative must be informed by the roofing contractor sufficiently in advance of the prejob conference and of when any roofing work will commence so that the job may be reviewed in advance, prejob conferences attended, and appropriate inspections scheduled.

02. Inspections deemed appropriate by T. CLEAR CORP. shall be made by a representative of T. CLEAR CORP. before, during and after construction.

## D. Deviations From Specification

01. There shall be no deviation made from T. CLEAR CORP. specifications without prior written approval by T. CLEAR CORP.

02. LG/HG PMR Insulation panels shall be installed in accordance with the most current T. CLEAR CORP. specifications in effect at the time of installation.

## E. Membrane Manufacturer Approval

01. LG/HG PMR Insulation panels shall not be applied over any membrane not currently approved for such use by T. CLEAR CORP.

---

A current list of acceptable membrane manufacturers may be obtained from the local T. CLEAR CORP. representative.

---

## 1.04 Submittals

A. Drawings shall be submitted to T. CLEAR CORP. for review.

B. Drawings shall include:

01. Roof plans, section and elevation details.

02. Location and type of all penetrations.

03. Description of surrounding building site and situation.

04. Membrane termination details.

05. Securement details for LG/HG PMR Insulation panels.

## 1.05 Related Specification Documents

A. ANSI/SPRI RP-4-2002.

B. T. CLEAR CORP. Technical Data Sheet 4.4.

C. T. CLEAR CORP. Technical Data Sheet #20.

## 1.06 Delivery, Storage, Handling

A. The insulation shall be shielded from sunlight when stored outdoors for extended periods. Cover with opaque, light-colored tarp for protection from solar radiation.

B. Insulation boards shall be handled with care so as not to damage the concrete surface, tongue or grooves.

C. Appropriate protective clothing shall be worn when handling the product. **Special precautions:** the concrete portion of this product may cause moderate skin irritation if handled during wet conditions such as when raining. To protect the skin while handling under such conditions additional protective equipment should include gloves and aprons.

## 1.07 Design Considerations

A. Structural Capability of the Deck

01. The roof loading, including the LG/HG PMR Insulation panels and the securement system, shall be determined by others and found sufficient for installation on the roof system. This is not the responsibility of T. CLEAR CORP.

B. Slope

01. Roof systems incorporating LG/HG PMR Insulation panels must be designed and constructed with positive slope in order to drain all water within 48 hours.

02. The maximum allowable slope for roof systems incorporating LG/HG PMR Insulation panels is 2/12. Slopes greater than 2/12 require technical approval.

C. Perimeter Roof Edge Terminations

01. The perimeter roof edge detail must be higher than the top of the perimeter paver securement in all cases.

D. Specific Instructions

01. In roof systems incorporating LG/HG PMR Insulation panels, an adequate thermal barrier should be provided between the insulation and the interior of the building. The thermal barrier may consist of the deck, a ceiling assembly, or an underlayment board equivalent to a 1/2 in. thick gypsum board. The thermal barrier may be omitted if performance has been demonstrated by a code accepted diversified test.

02. When loose applied sheet membranes are used, provisions must be made to permanently prevent any air infiltration to the space between the sheet membrane and the deck (see T. CLEAR CORP. Technical Data Sheet #20) including infiltration through the deck, all penetrations and terminations.

## 1.08 References

A. American Society for Testing and Materials (ASTM)

01. ASTM Test for Steady State Thermal Transmission Properties by Means of the Heat Flow Meter (C 518-91).

02. ASTM Test for Compressive Properties of Rigid Cellular Plastics (D 1621-73).

03. ASTM Test for Resistance of Concrete to Rapid Freezing and Thawing (C 666-92).

04. ASTM Specification for Prefabricated, Cellular Polystyrene Thermal Insulation (C 578-92s).

05. ASTM Specification for Austenitic Stainless Steel, Sheet, Strip, Plate, and Flat Bar for Structural Applications (A 666-82).

06. ANSI/SPRI RP-4-2002.

**B. T. CLEAR CORP. Technical Literature**

01. T. CLEAR CORP. Technical Data Sheet 4.4, Securement Requirements for LG/HG PMR Insulation Panels in a T. Clear Protected Membrane Roof System

02. T. CLEAR CORP. Technical Note 97.10, Repair of Damaged Concrete Surface on LG/HG PMR Insulation Panels.

03. T. CLEAR CORP. Technical Data Sheet #20, Guide to Achieve the Secured Single-Ply Roof.

**1.09 Maintenance**

**A. Owner’s responsibilities as a condition of the warranty include:**

01. Regular inspections of the roof system at least once every six months.

02. Maintenance and repairs to insure integrity of the system and perimeter securement.

**1.10 Warranty**

**A. T. Clear PMR Systems Warranty available as insulation and total system warranties.**

**A sample warranty may be obtained from the local T. CLEAR CORP. representative.**

**Part 2. Products**

**2.01 Manufacturers**

**A. Insulation**

01. LG/HG PMR Insulation Panels as manufactured by T. CLEAR CORP. utilizing extruded polystyrene ASTM D 578, Type VI.

**B. Fasteners**

01. Bulb Tite Fasteners, T. Clear Corp.

02. Fab Lok Fasteners, Elco Construction, 800-435-7213 ex 5430 for distributor.

03. Peel Rivet (LG) SFS Intec, Inc., 800-234-4533.

04. TRP 2 (HG), T. Clear Corp.

**C. Perimeter Metal Securement**

01. Metal Era, Inc., Waukesha, WI.

a. [“Anchor-Tite<sup>®</sup>” PMR/lock version fascia system.]

b. [“The Eliminator” PMR/lock version compression/retainer bar.]

c. [“Anchor-Tite<sup>®</sup>” PMR/lock Type 1 compression/retainer bar.]

02. Hickman, Ashville, NC.

a. [“The Leading Edge”]

**2.02 Materials**

**A. Cementitious Surfaced Foam Insulation**

01. The insulation shall be LG/HG PMR Insulation panels.

a. The size shall be 24 in. x 48 in. x [ ] inches (foam thickness) in thickness to achieve the desired U-factor through the complete roof system.

**LG/HG PMR Insulation Sizes**

	Width	Length	Thickness
LG	24 in.	48 in.	2 in., 3 in.
HG	24 in.	48 in.	2 in., 3 in.

b. The foam component of the LG/HG PMR Insulation panels shall have the following physical properties:

Typical 5-year aged R-value of 5.0 per sq. ft.-h-°F/Btu per in. of thickness when tested at 75°F mean temperature in accordance with ASTM C 518-76.

Minimum compressive strength of the foam insulation shall be 40 lbs. per sq. in. when tested in the vertical direction (at 10% deformation or yield, whichever occurs first) in accordance with ASTM D 1621-73.

The foam insulation component shall meet the physical properties requirements given in ASTM specification C 578-85, Type VI.

02. The composite insulation shall have the following properties:

a. Withstand freeze/thaw conditioning for a minimum of 750 freeze/thaw cycles in accordance with ASTM C 666 procedure B.

b. Minimum weight of 4 lbs. per sq. ft.

**B. Precast Pavers**

01. Pavers shall have compressive strength of 3000 lbs. per sq. in. and be of appropriate quality for roofing application.

02. Pavers shall be [nominal 2 in. x 8 in. x 16 in and weigh a minimum of 19 lbs.] [nominal of 2 in. x 2 ft. x 2 ft. and weigh a minimum of 88 lbs.]. Membrane type dictates paver needed.

**C. Factory Fabricated Perimeter Metal Securement**

01. [L-shape perimeter securement shall be [“Anchor-Tite<sup>®</sup>” PMR/lock version fascia system][“Anchor-Tite<sup>®</sup>” PMR/lock type 1 compression/retainer bar.]

02. [J-shape perimeter securement shall be “The Eliminator” PMR/lock version compression/retainer bar.]

03. [Hickman “The Leading Edge”.]

#### D. Field and Shop Fabricated Metal Securement

01. [Counter flashing/gravel stop perimeter metal securement detail must be fabricated to extend a minimum of 6 in. onto the surface of the LG/HG PMR Insulation panels and meet all material requirements stated in this section.]

02. Metal securement shall be minimum 22 ga. (0.0284-0.0314) ASTM grade 304 stainless steel [ASTM AZ55, Galvalume or Zinalume].

03. Metal securement shall have a maximum continuous length of 12 ft.

**A longitudinal crimp or break in the metal securement is recommended to achieve stiffening.**

#### E. Fasteners

**Fastener length will depend on the type of perimeter securement system specified. Factory fabricated perimeter metal securement systems require fasteners with a longer grip range. The fastener specified for factory fabricated perimeter metal securement may be used with other securement systems.**

01. Fasteners for metal attachment to LG/HG PMR Insulation panels shall be:

- [FABCO FAB-LOK EZJ250]
- [Olympic BULB-TITE blind rivet 6604-8-10]
- [PEEL RIVET minimum 1/4 in. diameter 1-1/4 in. length]
- TPR-2 for HG.

02. Fasteners for attachment of metal securement to structure shall be:

- [TAPCON with Climaseal coating, ITW BUILDEX, Olympic RUFF-NEX part #RNA-134-3 or approved equal]
- A minimum 3/16" diameter
- Penetrated a minimum of 1-1/4" into substrate (treated wood, brick or concrete)

- A Minimum pull out of 200 lbs.
- Nails not acceptable

**LG/HG PMR Insulation panels should be installed, and remain, unadhered since flotation may occur. Some membranes such as coal tar, Type I or Type II asphalt and certain liquid membranes, remain "tacky" and require installation of a slip sheet to prevent adhesion of the foam. In circumstances where insulation is not compatible with the membrane, consult manufacturer for an approved separator sheet.**

F. Air Filtration Seal  
(See T. CLEAR CORP. Technical Data Sheet #20, A Guide To Achieve The Secure Single-Ply Roof).

#### G. [Slip Sheet]

01. The slip sheet, where required, shall consist of a polyethylene film, 4 mil or greater in thickness.

### Part 3. Execution

#### 3.01 Preparation

A. Protection of the LG/HG PMR Insulation panels during installation.

01. LG/HG PMR Insulation panels not fully installed shall be provided with temporary ballast to prevent wind disturbance or board movement due to flotation.

02. LG/HG PMR Insulation panels not fully installed must be protected from construction damage. Completed roof systems should not be used as construction staging area or for storage.

#### B. Air Infiltration Seal

01. An air seal shall be installed in accordance with T. CLEAR CORP. Technical Data Sheet #20, A Guide To Achieve The Secure Single-Ply Roof.

#### 3.02 [Membrane Installation]

A. The membrane shall be installed in accordance with T. CLEAR CORP. and membrane manufacturer's specifications.

B. Loose laid single-ply sheet membrane installation shall comply with requirements of T. CLEAR CORP. to prevent air infiltration (see T. CLEAR CORP. Technical Data Sheet #20).

**Membranes that require installation of a slip sheet include:**

- Coal tar bitumen BUR
- Type I or II Asphalt BUR
- Some liquid applied membranes
- Membrane resaturated within previous four years.
- Some PVC membranes

#### 3.03 [Slip Sheet Installation]

A. A slip sheet shall be installed, where required, over membranes that may adhere to LG/HG PMR Insulation panels or when required by the membrane manufacturer.

01. Install slip sheet over the membrane overlapping edges by a minimum of 1 in.

**The following should be used when multi-layer installations of extruded polystyrene insulation are being considered for use under LG/HG PMR Insulation panels.**

#### 3.04 [Multi-layer Installations of Extruded Polystyrene and LG/HG PMR Insulation]

A. Layer(s) of insulation underlying the LG/HG PMR Insulation panels must be extruded polystyrene with a minimum compressive strength of 40 lbs. per sq. in.

B. The lower layer must be equal to or thicker than the thickness of the LG/HG PMR Insulation panels.

C. All joints shall be staggered in relation to other layer(s).

D. All layers shall be installed unadhered.

Figure 1A. Correct Installation Staggered Array

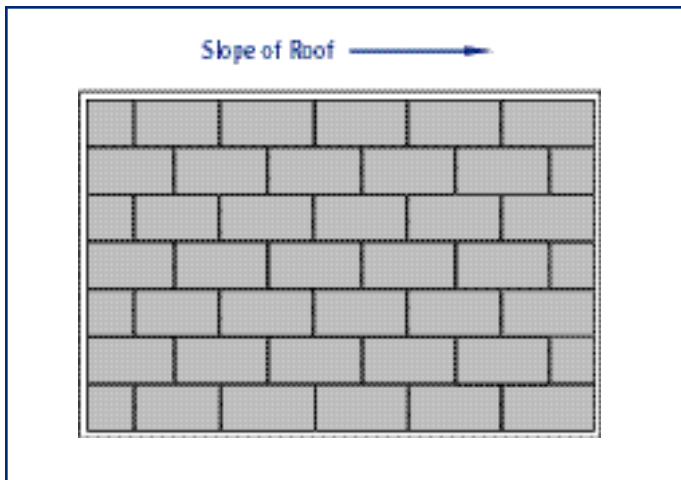
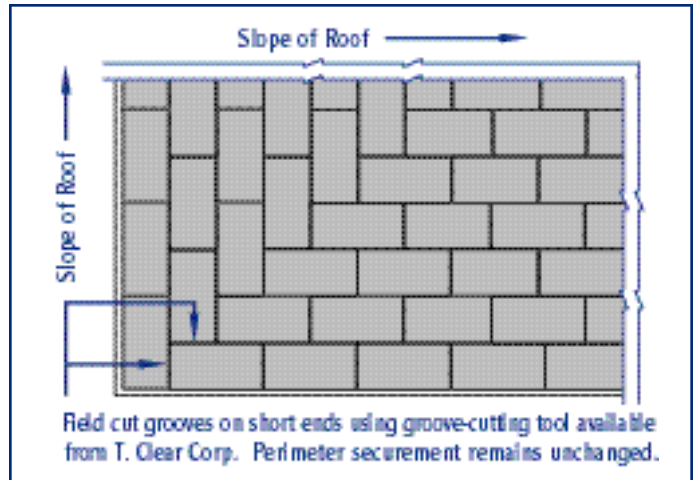

Figure 1B. Alternative Installation Staggered Array



### 3.05 LG/HG PMR Insulation Panels Installation

#### A. Commencing installation of LG/HG PMR Insulation panels.

01. Always start at a corner close to the source of the prevailing wind. Work from the bottom of slope to the top (See section 3.05 B 05).

02. Start the first row with a whole board at a corner with groove side towards the edge of the roof. Snap a chalk line the width of one board (2 ft.) away from the perimeter edge as a guide. Lay the boards tightly in the row.

03. To obtain a stagger, the second row of boards should begin with a half board. Two additional chalk lines at 90 degree angles to the first at 4 ft. and 6 ft. away from the perimeter edge should be snapped to help maintain end stagger by indicating starter lines for the ends of the first boards in the next rows.

04. Once the array is started it must be continued across the entire roof area.

05. Insulation boards shall be cut using masonry saw blades.

#### Figure 2. Correct Termination

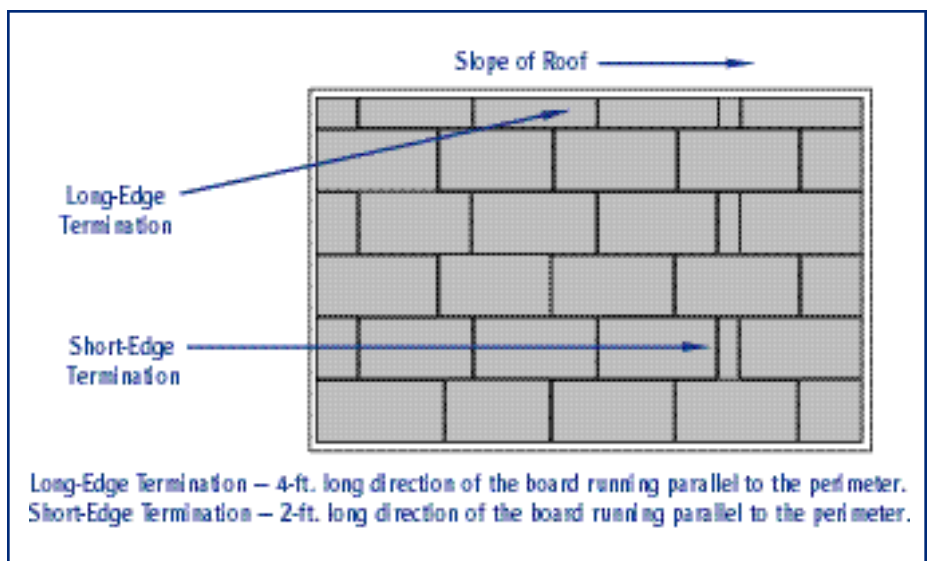

#### B. General Placement of Insulation Boards.

01. Tight tongue and groove integrity (with no gaps greater than 1/4 in.) and a staggered-joint array must be maintained ([ Fig. 1A] [Fig. 1B]).

02. Boards must remain unadhered to the membrane.

03. All sides of the boards must be tightly butted to the adjacent boards.

04. The concrete mortar surface on the boards must not be in contact with terminations such as parapets, curbs, etc. Use of 1/2 in. thick polyethylene foam is suggested.

05. Boards shall be laid with 4 ft. long side in the direction of the roof slope. Array should begin at the bottom of steep roof slopes and be continued to the roof peak. This is most critical for roof slopes greater than 1/2 / 12. ([Fig. 1A][Fig. 1B]).

Figure 3. Correct Termination Piece, Long-Edge Termination

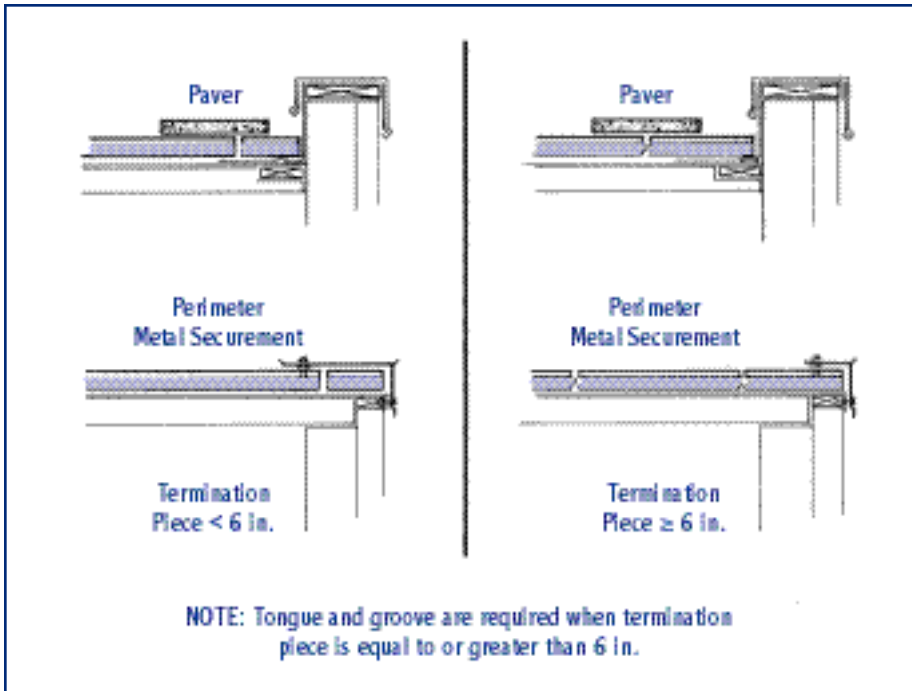
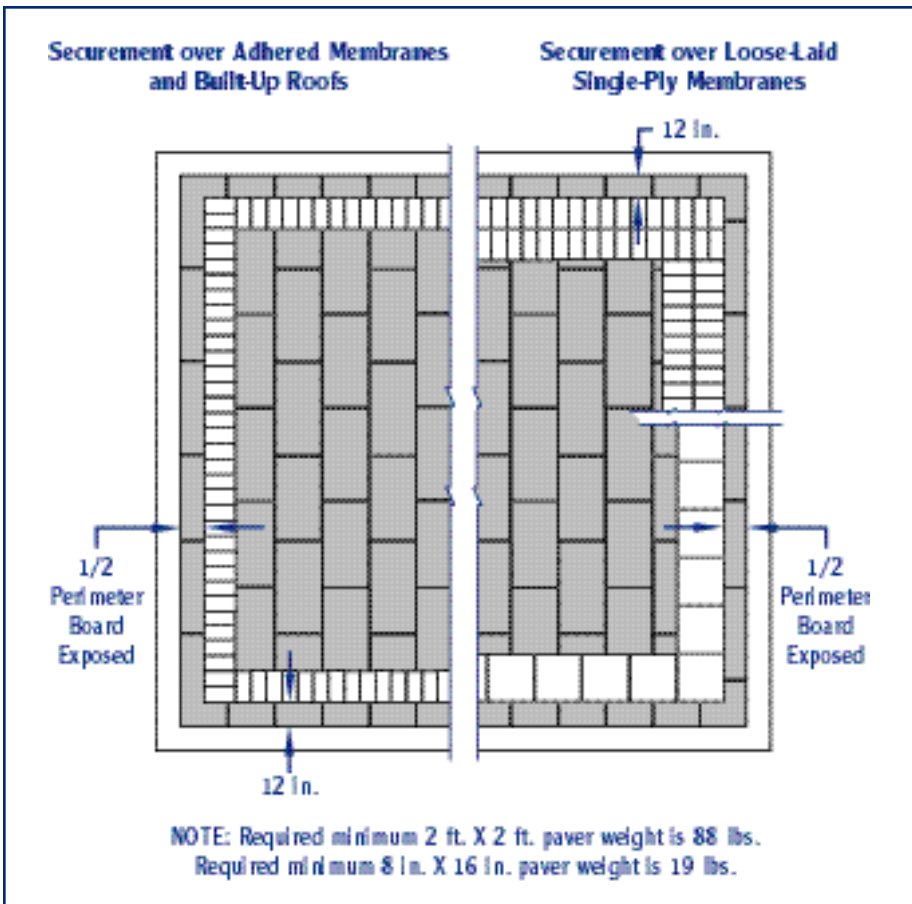

Figure 4. Roof Plan of Paver Layout



C. Placing Insulation Boards Across Slope Changes

01. Insulation units shall be cut to conform to slope changes on the deck and to prevent breakage of boards spanning across slope changes.

02. Additional securement must be added if tongue and groove or staggered joint array is compromised or if boards are cut to lay flat on adjacent planes.

03. Small cut pieces must not be used in the system where a full board or a larger piece can be used.

The direction in which the insulation boards are laid will affect how well the boards will conform to slope changes without being cut. Laying insulation boards over uneven portions of the roof deck may cause the concrete surface to crack. This cracking alone will not adversely affect system or product performance but breakage exposing insulation may.

Insulation boards must not bridge over uneven portions of the deck. That will cause the insulation units to break (a crack through the concrete and the insulation). In these cases during installation the boards must be cut and additional securement added. In certain cases an appropriate piece of cut insulation may be placed under the LG/HG PMR Insulation panels to even the deck.

D. Terminations

01. Panels must be a maximum of 1/2 in. from all terminations or penetrations. The insulation may be beveled to conform to the slope of cant strips.

02. [Boards must be terminated immediately adjacent to drain bonnet.] [Boards may be installed over the drains where the drain opening has

Figure 5. Long-Edge &amp; Short-Edge Perimeter Termination

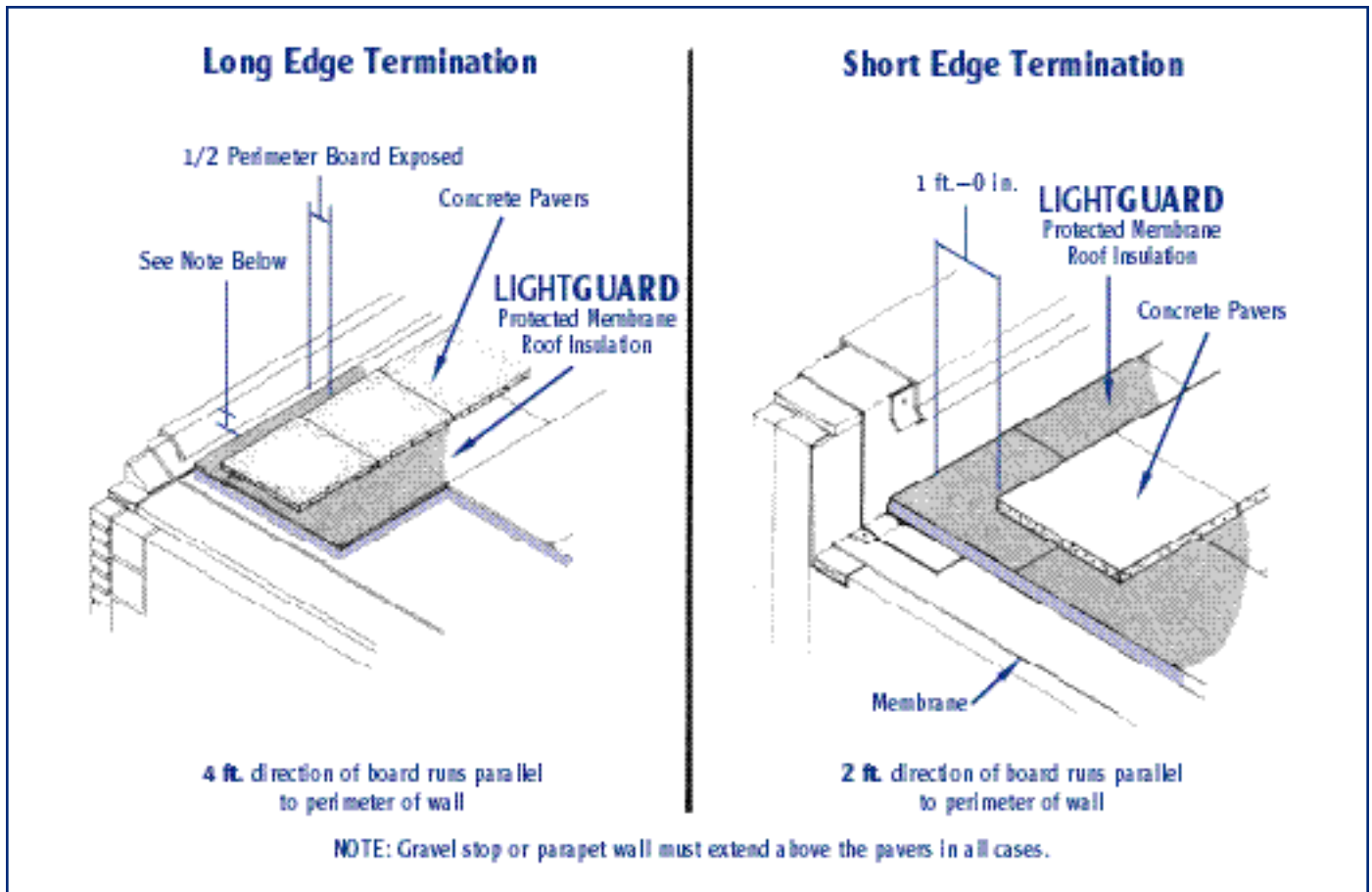

been protected using a flat perforated metal cover. The boards should be marked to indicate the drain.]

### 03. Perimeter terminations ( Fig. 2)

#### a. Long-Edge Termination:

Perimeter termination method when 4 ft. long edge of board is against the perimeter. Pieces with width equal to or greater than 6 in. must be placed into position with tongue and groove integrity. For terminating pieces less than 6 in. wide, tongue and groove is not required (Fig. 3).

#### b. Short-Edge Termination:

Perimeter termination method when 2 ft. long edge of board is against the perimeter. Boards ending a row with lengths less than 6 in. may be moved into the array of the roof as the second board from the perimeter.

04. All foam exposed directly to the sun shall be coated with exterior grade latex paint or otherwise protected.

### 3.06 Perimeter Securement

The installed system must be secured at all perimeters. The securement system must restrain any movement of the roof insulation at termination points.

**There are two methods used in securing LG/HG PMR Insulation panels at the perimeter:**

1. The preferred method, uses fabricated metal counter flashing/gravel stop securement piece or an extruded aluminum factory fabricated metal securement piece.

2. The use of concrete pavers.

### A. [Metal Perimeter Securement]

#### 01. Metal Perimeter Edge Securement

a. [Metal counter flashing/gravel stop securement.] The metal counter flashing/gravel stop securement shall extend a minimum of 6 in. onto the surface of the LG/HG PMR Insulation panel and be attached 18 in. on center using approved fasteners. Fasteners must be 3 in. minimum from any board edge ( Fig. 6 and 7).

**The following two options are factory prefabricated perimeter metal securement for use as alternatives to shop fabricated perimeter metal securement.**

Figure 6. Gravel Stop Perimeter Securement Long-Edge Perimeter Termination

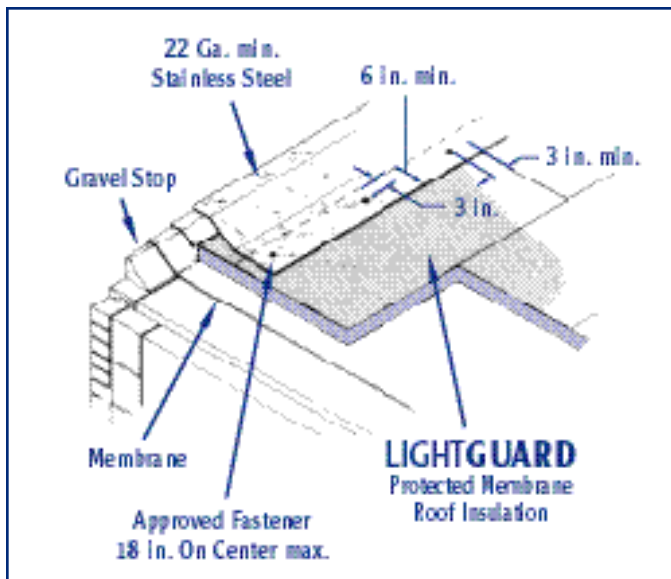
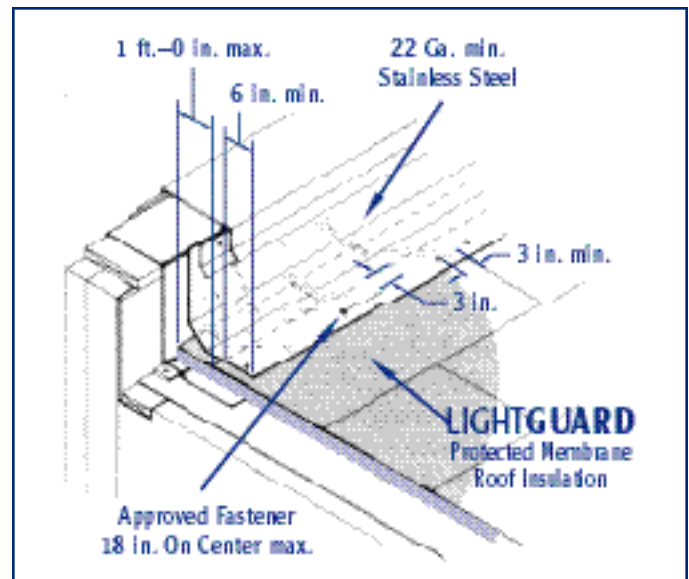

Figure 7. Wall Counter Flashing Perimeter Securement Long-Edge Perimeter Termination



b. [Factory prefabricated metal counter flashing/gravel stop securement.] Install [L-shape] [J-shape] metal securement in accordance with the manufacturer's instructions (See Fig. 9 for L-shape configuration).

02. The metal perimeter edge securement shall be securely attached to the perimeter edge wood nailer or wall a maximum of 12 in. on center using appropriate fasteners, providing minimum 200 lb. pull resistance.

03. The metal perimeter edge securement shall not run for continuous lengths over 12 ft. Proper considerations for coefficient of expansion/contraction and corrosion must be incorporated in the design of the metal and fasteners.

04. The metal perimeter edge securement must be attached to a terminating board that has tongue and groove integrity and is equal to or greater than 6 in. wide. If the termination board is less than 6 in. wide, the metal perimeter securement must be extended a minimum of 6 in. onto the surface of the next whole board in and be attached a maximum of 18 in. on center ( Fig. 3).

05. When perimeter drainage is used (i.e. gutter edge detail) the perimeter securement must be perforated and constructed from minimum 18 gauge stainless steel (See Detail No. TCC-D-7-95-A, Drawing No. 7).

B. [Paver Securement] ( Fig. 4)

**The amount of paver ballast required depends on the type of membrane used and on whether multiple insulation layers are installed. The following minimum ballast requirements must be met for:**

01. [Adhered membranes]

a. For roofs in 90 mph wind range only, securement shall be a single row of nominal 2 in. x 8 in. x 16 in. pavers laid with their long edge perpendicular to the roof perimeter. (See T. CLEAR CORP. Technical Data Sheet 4.4)

02. [Loose-laid membranes and multiple layer foam installations.]

a. For roofs in 90 mph wind range only, securement shall be a single row of nominal 2 in. x 2 ft. x

2 ft. or two rows of nominal 2 in. x 8 in. x 16 in. pavers laid with their long edge perpendicular to the roof perimeter. (See T. CLEAR CORP. Technical Data Sheet 4.4)

03. Paver placement ( Fig. 4)

a. The height of gravel stop or parapet shall extend above the paver in all cases ( Fig. 5).

b. Pavers shall be placed in continuous rows butted together at all perimeters and openings or penetrations greater than 4 ft. long (See section 3.07 B for securement at internal penetration).

c. When the 4 ft. long direction of the board runs parallel to the perimeter, pavers shall be placed with their outside edge centered on the perimeter board (covering the first board joint) ( Fig. 5, Long-Edge Termination ). When the 2 ft. long direction of the board runs parallel to the perimeter pavers shall be placed in from the perimeter at least 12 in. ( Fig. 5, Short-Edge Termination ).

### 3.07 Securement Where Tongue and Groove Integrity Has Been Lost

#### A. Interruptions in Tongue and Groove Integrity

01. Whenever tongue and groove integrity is lost or cuts are made through the boards, securement shall be added to tie the system together using:

- a. [A metal strap, 8 in. wide minimum, centered on the break and fastened on both edges, 12 in. on center (Fig. 8 & 9). The strap must extend a minimum of 4 in. onto the face of the board and the fasteners must be a minimum of 3 in. from edges.] [Minimum 19 lb. 2 in. x 8 in. x 16 in. paver placed in continuous rows on each side of the cut, laid with their long edge perpendicular to the cut.]

#### B. Internal Penetrations

01. All penetrations greater than 4 ft., but less than 12 ft. in any direction shall be secured with [pavers 2 in. x 8 in. x 16 in. laid with their long edge perpendicular to the internal penetration] [minimum 3 in. wide, 22 gauge metal strap secured a maximum of 12 in. on center (Fig. 11).

02. Internal penetrations greater than or equal to 12 ft. in any direction must be secured in the same manner as the perimeter.

Figure 8. Alternative Strapping Securement

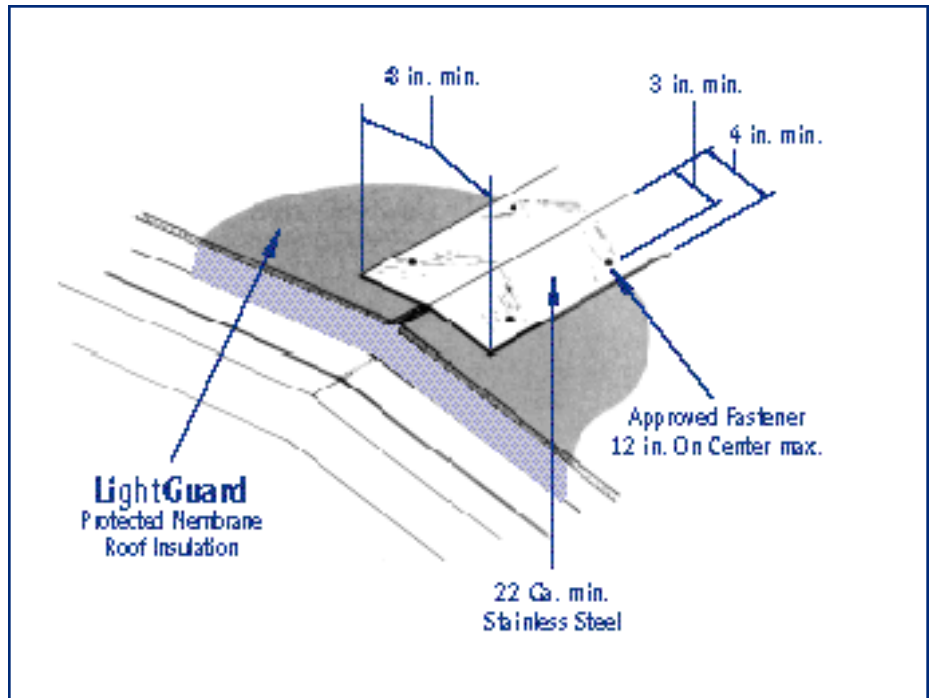
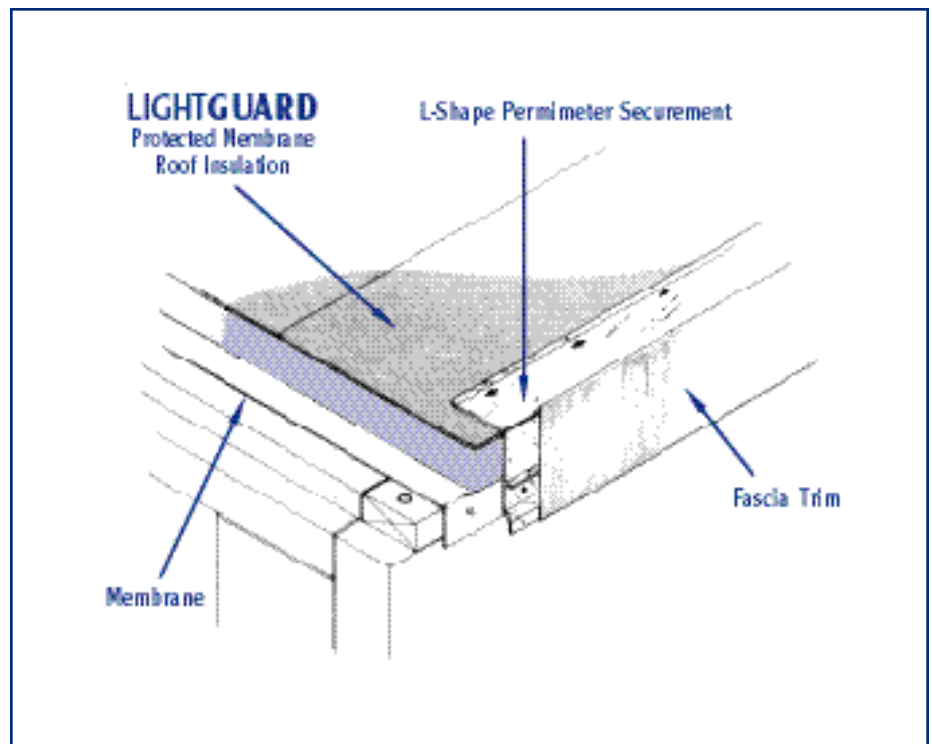

Figure 9. Factory Prefabricated L-Shape Metal Perimeter Securement "Anchor-Tite" PMR/Lock Version Fascia System by Metal-Era, Inc.



### 3.08 Fasteners

#### A. Installation of Fasteners

01. All fastener manufacturer's installation specifications must be followed.

02. Fasteners must be placed in a predrilled hole when installed into the LG/HG PMR Insulation panels, with the hole size specified by the fastener manufacturer. Hammer type drills must not be used in drilling the holes.

03. Fasteners must not be over-driven and must be perpendicular to the appropriate plane.

04. Correct drill bits and tools as recommended by the product manufacturer shall be used to ensure proper fastener installation.

05. Fasteners shall be placed a maximum of 18 in. on center for attaching perimeter edge securement and a maximum of 1 ft. on center for attaching securement where tongue and groove integrity has been lost. Fasteners shall be placed a minimum of 3 in. from any of the insulation board edges.

**WARNING: LG/HG PMR Insulation is combustible and may constitute a fire hazard if improperly used or installed. It should be adequately protected. Use only as directed by the specific instructions for this product. During shipping, storage, installation and use, this material should not be exposed to flame or other ignition sources. All roofing deck systems over which LG/HG PMR Insulation panels are installed should provide an adequate fire barrier or have passed a code accepted diversified test. For proper protection of LG/HG PMR Insulation panels during storage, consult your insurer, your local fire department or other authority having jurisdiction.**

Figure 10. Metal Securement Around Internal Penetration.  
Tongue & Groove Integrity Compromised

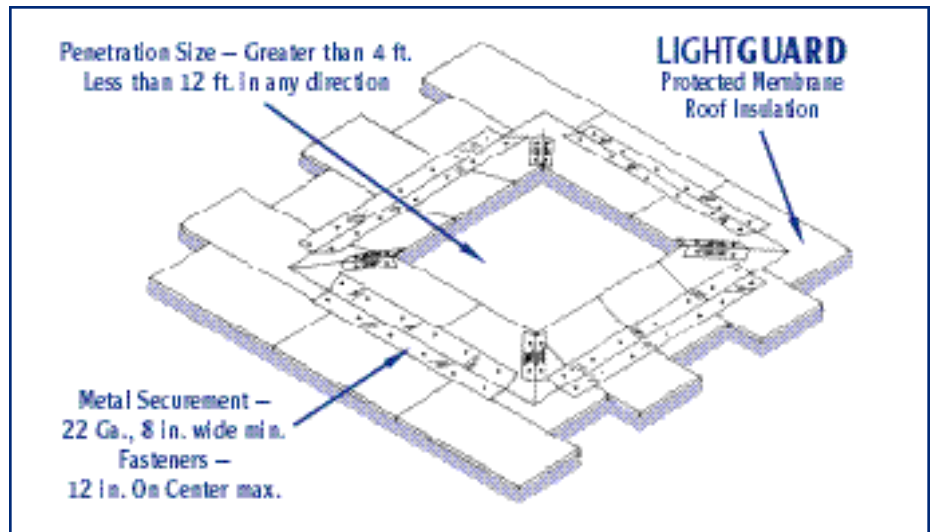
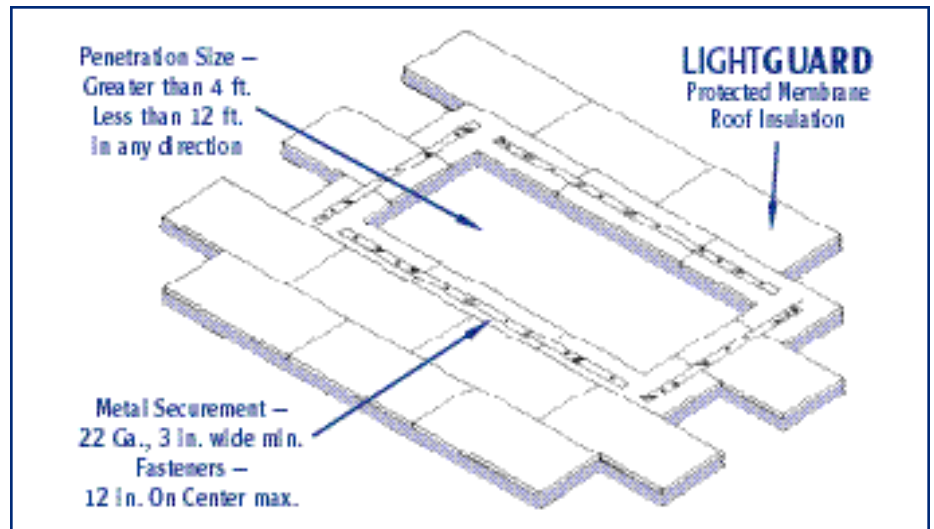

Figure 11. Metal Securement Around Internal Penetration.  
Tongue & Groove Integrity Maintained



®LIGHT GUARD and HEAVY GUARD are registered trademarks of T. Clear Corporation.

NOTICE: T. CLEAR CORP. believes the information and recommendations herein to be accurate and reliable as of May, 2005. However, since any assistance furnished by T. CLEAR CORP. with reference to the proper use and disposal of its products is provided without charge, and since use conditions and disposal are not within its control, T. CLEAR CORP. assumes no obligation or liability for such assistance and does not guarantee results from use of such products or other information herein; no warranty, expressed or implied, is given nor is freedom from any patent owned by T. CLEAR CORP. or others to be inferred. Information herein concerning laws and regulations is based on U.S. federal laws and regulations except where specific reference is made to those of other jurisdictions. Since use conditions and governmental regulations may differ from one location to another and may change with time, it is the Buyer's responsibility to determine whether T. CLEAR CORP.'S products are appropriate for Buyer's use, and to assure Buyer's workplace and disposal practices are in compliance with laws, regulations, ordinances, and other governmental enactments applicable in the jurisdiction(s) having authority over Buyer's operations.



3255 Symmes Road  
Hamilton, OH 45015  
1-800-544-7398

[www.tclear.com](http://www.tclear.com)

©2005 T. Clear Corp.